

PS PATROL® System

Provides convenient wiring connection and system monitoring for pump station applications.

The PS Patrol® system features a built-in high water alarm and provides a convenient location to connect all wiring required for a pumping station installation. The PS Patrol® system employs a receptacle to accept a 120 VAC pump and piggy-back style pump switch.

The sleek, angled design of the clear enclosure includes a **removable cover** for easy access for field wiring. All internal components are sealed within the cover for protection from the elements. The **red LED illuminates the cover** in an alarm condition for easy 360° visual identification. Available with or without 32" mounting post.



Shown with Mounting Post
U.S. Patent Nos. D 780,703 and 9,472,932

STANDARD FEATURES

- Controller meets Type 3R watertight standards and is designed for outdoor use
- Built-in high water alarm
- Removable cover provides greater access for field wiring and service
- Controller can be purchased with standard 5" square plastic post or can be mounted on 4" schedule 40/80 PVC pipe or conduit (customer supplied)
- Automatic alarm reset, horn silence and alarm test
- 360° visual alarm; audible alarm
- Red LED illuminates cover in alarm condition
- Green Power On light
- Auxiliary alarm contacts included for easy attachment of remote alarm
- Receptacle for easy connection of pump and piggy-back pump switch
- Cord seal included for sealing switches and pump cable
- Electrical potting cavity provides easy reliable method to seal power cables. (User to provide duct seal)
- CSA Certified
- Five-year limited warranty



OPTIONS

- Mercury or mechanical pump switches
- Various cord lengths
- Riser assembly adapter
- Dual alarm (2nd alarm input - Yellow LED illuminates cover in alarm condition)
- Elapsed Time Meter (ETM)
- Pump circuit breaker
- Available with or without 32" post

SPECIFICATIONS

ALARM VOLTAGE: 120 VAC

PUMP VOLTAGE: 120 VAC

ENCLOSURE SIZE:

Controller with post 5" X 5" X 39"
Controller without post 5" X 5" X 8"

RECEPTACLE: 120 VAC - NEMA Type 5-15

AUXILIARY CONTACTS 120 VAC

0.5 amps max., 50/60 Hz
(circuit not supervised)

ALARM HORN: 82 decibels at 10 feet

ALARM FLOAT: SJE SignalMaster® control switch with mounting clamp

**SEE REVERSE SIDE FOR ORDERING INFORMATION.
SEE PRICE BOOK FOR LIST PRICE.**



SJE RHOMBUS

PO Box 1708, Detroit Lakes, MN 56502

1-888-DIAL-SJE • 1-218-847-1317

1-218-847-4617 Fax

email: customer.service@sjeinc.com

www.sjerrhombus.com **B.73**

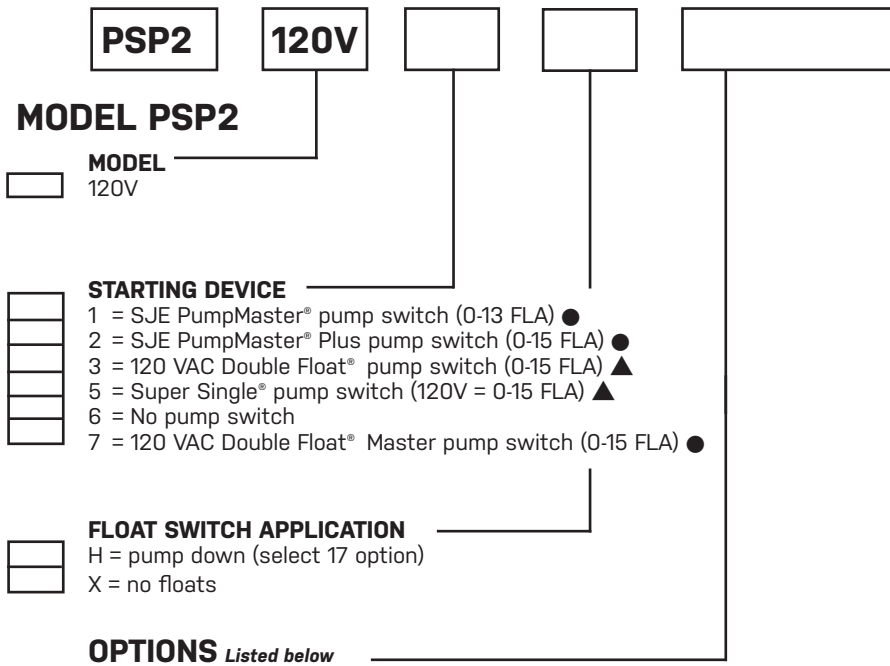

- CODE DESCRIPTION**
- 1J Duo alarm inputs
 - 1V Vertical Reed Switch (*must select 1J*)
 - 8A Elapsed time meter
 - 10X No Mounting Post
 - 15_P Pump breaker
specify 0 or 1 after number 15 followed by letter "P"
0 = 15 amp breaker (0-7 FLA)
1 = 20 amp breaker (7-15 FLA)
(Ex. 151P = 20 amp breaker, 7-15 FLA)

- CODE DESCRIPTION**
- 16A 10' cord in lieu of 20' (*per float*)
(Does not apply for Double Float® or Double Float® Master pump switch)
 - 16B 15' cord in lieu of 20' (*per float*)
 - 16C 30' cord in lieu of 20' (*per float*)
 - 16D 40' cord in lieu of 20' (*per float*)
 - 17A SJE SignalMaster® / pipe clamp (*alarm float*) ●
 - 17J Sensor Float® / pipe clamp (*alarm float*) ▲
 - 22F PSP Assembly Kit

● Mechanically-activated ▲ Mercury-activated

Part Number	Model Number	Description	FLA	Ship Weight
1022728	PSP2120V6H17A	PSP2 120V, no pump switch, 20' SJE SignalMaster®, with mounting post	0-15	13 lbs.
1019021	PSP2120V6H151P17J	PSP2 120V, no pump switch, 20' Sensor Float®, 20A circuit breaker, with mounting post	7-15	13 lbs.
1022575	PSP2120V6H8A17A	PSP2 120V, ETM, 20' SJE SignalMaster®, with mounting post	0-15	14 lbs.
1022577	PSP2120V6H1JV8A17A	PSP2 120V, Duo alarm, ETM, 20' SJE SignalMaster® & VRS, with mounting post	0-15	15 lbs.
1018434	PSP2AB6H16B17A	PSP2 120V, no alarm, no pump switch; remote TAAB, 15' SJE SignalMaster®, with mounting post	0-15	16 lbs.
1011551	Assembly Kit	Riser Extension Coupling and Washers	n/a	10 lbs.



SJE RHOMBUS

www.sjrhombus.com
customer.service@sjinc.com